

view with optional mounting clamp

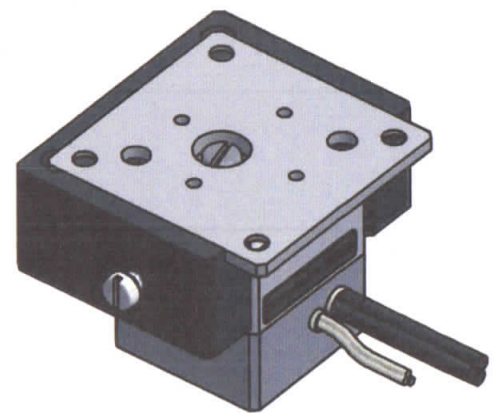

part.no. K-190-00

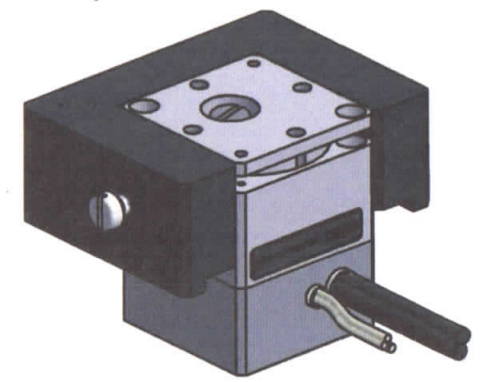

**standard designs:**

- cable length cl SG 1,2m with connector LEMO FFP.0S.302
- cable length EXT 2m with connector LEMO FFP.0S.302 and ODU 4pin
- cable length DIG 2m with connector DSUB 15pin

X, Z: 2 active tip/tilt axes (without z-motion)

X, Y, Z: 3 active tip/tilt axes + z-motion

**ORIGINAL**

		PSH 1 SG		PSH 2 SG		PSH 3 SG		PSH 4 SG	
	tilt axes	XYZ	XZ	XYZ	XZ	XYZ	XZ	XYZ	XZ
part.no.	tilting plate A	K-201-11	K-201-31	K-202-11	K-202-31	K-203-11	K-203-31	K-204-11	K-204-31
	tilting plate B	K-201-21	K-201-41	K-202-21	K-202-41	K-203-21	K-203-41	K-204-21	K-204-41
H height		32		41		50		59	

part.-no. K-20(1...4)-X1		part.-name PSH 1...4 (z) SG (A/B)	
file name PK-20(1...4)-X1.idw	rev.01	OK: date/sign. 17. DEZ. 2021	
		scale 1:1	customers drawing piezosystem jena